



Vestil Manufacturing Corp.

2999 North Wayne Street, P.O. Box 507, Angola, IN 46703

Telephone: (260) 665-7586 -or- Toll Free (800) 348-0868

Fax: (260) 665-1339

www.vestilmfg.com

info@vestil.com

HOP-LP Portable Steel Dumping Hoppers



Receiving Instructions

After delivery, remove the packaging from the product. Inspect the product closely to determine whether it sustained damage during transport. If damage is discovered, record a complete description of it on the bill of lading. If the product is undamaged, discard the packaging.

NOTE: The end-user is solely responsible for confirming that product design, use, and maintenance comply with laws, regulations, codes, and mandatory standards applied where the product is used.

Technical Service & Replacement Parts

For answers to questions not addressed in these instructions and to order replacement parts, labels, and accessories, call our Technical Service and Parts Department at (260) 665-7586. The department can also be contacted online at http://www.vestilmfg.com/parts_info.htm.

Electronic Copies of Instruction Manuals

Additional copies of this manual may be downloaded from <https://www.vestil.com/page-manuals.php>.

Table of Contents

	Page
Specifications	2
Signal Words	2
National Standards	3
Safety Instructions	3
Exploded View and Bill of Materials	4
Using the Caster Brake	5
Assembling the Hopper	5 - 6
Loading & Using the Hopper	7 - 8
Record of Satisfactory Condition	8
Inspections & Maintenance	8 - 9
Labeling Diagram	9
Limited Warranty	10

SPECIFICATIONS

Documents that provide specifications for HOP-LP-series hoppers are available online to anyone who visits Vestil's website. Specifications include dimensions, net weight, and capacity information. To access the appropriate specifications document, navigate to <https://www.vestil.com/product.php?FID=451>. Scroll to the *Product Specifications Table* portion of the page. Find the entry for the hopper you purchased and click the button in the "PDF" column that looks like a pencil inside a blue-bordered box. A PDF file will open. This file is the specifications document. Print a copy of the document and keep it with your copy of this manual. The following is an exemplar specifications document.

LOW PROFILE PARTS HOPPER - HOP-LP

*** ANY ADDITIONS, DELETIONS, OR OMISSIONS MUST BE CORRECTED ON THIS DRAWING AS THIS DRAWING WILL BE CONSIDERED ALL INCLUSIVE ***
ALL GRAPHICS PROVIDED ARE FOR REFERENCE ONLY. IF CERTAIN DIMENSIONS ARE CRITICAL PLEASE VERIFY THOSE DIMENSIONS WITH YOUR SALESPERSON

APPROX WEIGHT: 294.50 lbs.
DOES NOT INCLUDE WEIGHT OF POWER OR PACKAGING!!!

REMOVABLE HANDLE

LOAD CENTER

CENTER OF GRAVITY

DUMPED POSITION

4" X 2" GLASS FILLED NYLON RIGID CASTERS

2 SWIVEL 4" X 2" GLASS FILLED NYLON CASTERS: ONE W/ SIDE BRAKE

APPROX. WEIGHT/ LOST LOAD=294.50 LBS.
EFFECTIVE THICKNESS= FORK LENGTH MINUS 21 3/4"

NEVER EXCEED LOAD CENTER RATING PER FORK TRUCK MANUFACTURER'S GUIDELINES. DO NOT USE THIS FORK TRUCK ATTACHMENT IF LOAD WILL EXCEED FORK TRUCK MANUFACTURER'S LOAD CENTER RATING.

STANDARD FEATURES

MODEL NUMBER: HOP-LP
CAPACITY: 2,000 LBS.
VOLUME: 1/2 CUBIC YARD
OVERALL WIDTH: 48 7/16"
OVERALL LENGTH: 54 1/16"
OVERALL HEIGHT: 34"
WORK ENVELOPE: 48 7/16" X 57 11/16" X 55 3/4"
CHUTE SIZE: 48 7/16" X 44 11/16" X 13 3/4"
RELEASE CABLE LENGTH: AT LEAST 48"
FORK POCKETS: 7"W X 2"H, 21 5/8" ON CENTER
1-SWIVEL 4" X 2" GLASS FILLED NYLON CASTERS W/ LOCK
1-SWIVEL 4" X 2" GLASS FILLED NYLON CASTER
2-RIGID 4" X 2" GLASS FILLED NYLON CASTERS
TOUGH BAKED IN POWDER COATED BLUE FINISH

SPECIAL FEATURES

NONE

APPROVAL

I, THE UNDERSIGNED, AGREE THAT THE PRODUCT AS REPRESENTED SATISFIES DESIGN AND DIMENSION REQUIREMENTS. I ALSO ACKNOWLEDGE MY DUTY TO CONFIRM PRODUCT AND INSTALLATION COMPLIANCE WITH ALL APPLICABLE FEDERAL, STATE AND LOCAL REGULATIONS AND STANDARDS.

ANY MODIFIED UNITS ARE NON-RETURNABLE

[] As drawn [] As marked

Signed: _____ Date: _____

Printed Name: _____

LEAD TIME WILL START UPON RECEIPT OF SIGNED APPROVAL DRAWING

FOR INTERNAL USE ONLY PROJECT SIGN OFF		DISTRIBUTOR'S NAME: VESTIL MANUFACTURING		P.O.# X
SALES		DRAWN BY: CA	DATE: 2/20/2013	W.O.# X
ENG.		REFERENCE: X	SCALE: 1:15	SALES: X
FAB.		QUOTED LEAD TIME: X	QUOTE # X	FILE NAME: 37-007-031
POWER				

NOTE: If your model is either not included on the webpage or you cannot access and/or print the document, contact the [Technical Service Dept.](#) Contact information is provided on the front page of this manual.

SIGNAL WORDS

SIGNAL WORDS appear in this manual to draw the reader's attention to important safety-related messages. The following are signal words used in this manual and their definitions.

- DANGER**

Identifies a hazardous situation which, if not avoided, WILL result in DEATH or SERIOUS INJURY. Use of this signal word is limited to the most extreme situations.
- WARNING**

Identifies a hazardous situation which, if not avoided, COULD result in DEATH or SERIOUS INJURY.
- CAUTION**

Indicates a hazardous situation which, if not avoided, COULD result in MINOR or MODERATE injury.
- NOTICE**

Identifies practices likely to result in product/property damage, such as operation that might damage the product.

NATIONAL STANDARDS

US OSHA Rule 1910.178 (29 CFR 1910.178; the "Rule") classifies this device as a "front- end attachment" whenever it is mounted on a lift truck. The Rule incorporates American National Standard ANSI/ITSDF B56.1 (the "Standard"). The Standard is published by the Industrial Truck Standards Development Foundation on its website (www.itsdf.org) where it is freely downloadable at <http://www.itsdf.org/cue/b56-standards.html>. Acquire a copy of the Standard *before putting this device into service*. Apply all relevant parts of Part II: For the User. If instructions provided in this manual apparently conflict with the Standard, then apply the instructions in the Standard. Vestil requests that you immediately share any conflicts you discover with its [TECHNICAL SERVICE](#) personnel. Contact information is provided on the cover page of this manual.

SAFETY INSTRUCTIONS

Vestil strives to identify foreseeable hazards associated with the use of its products, but no manual can address every possible risk. Minimize the likelihood of injury by recognizing the hazards identified below and by inspecting and maintaining the product as instructed in [INSPECTIONS & MAINTNENANCE](#) on p. 8 -9. Apply all portions of ANSI/ITSDF standard B56.1, Part II "For the User" that concern the use of attachments and removable attachments. The following recommendations are intended to complement the provisions of the Standard.

WARNING

Risks of serious personal injuries or death.

- **Read and understand the entire manual before assembling, using, inspecting, or servicing the hopper.**
- Before this product may be used, U.S. Occupational Safety and Health Administration rule 1910.178(a)(4) and (a)(5) require that the owner/user: 1) Obtain written approval from a professional engineer or from the manufacturer(s) of all forklifts that will use the hopper; 2) Change all forklift capacity, operation, and maintenance instruction plates, tags, or decals accordingly; AND 3) Mark the forklift truck to identify the hopper and show the approximate weight of the truck and hopper combination at maximum elevation with load laterally centered. See <https://www.osha.gov/laws-regs/regulations/standardnumber/1910/1910.178>
- Inspect the hopper as directed in the [INSPECTIONS & MAINTENANCE](#) section on p. 8 - 9. DO NOT use it unless it is in [SATISFACTORY CONDITION](#). See [RECORD OF SATISFACTORY CONDITION](#) on p. 8.
- DO NOT use the hopper if the carriage chain is damaged or missing.
- DO NOT lift the hopper until it is securely connected to the carriage of the fork truck with the carriage chain. ONLY use this hopper with a powered forklift truck. DO NOT mount the hopper on stackers or manually propelled lift trucks.
- DO NOT fill the hopper with a load weighing more than its 2,000 pounds (909.1kg) maximum rated load (capacity). Capacity information is provided on your specifications document. Unit capacity also appears on label 1153. See [LABELING DIAGRAM](#), p. 9.
- DO NOT travel under the hopper at any time while it is elevated.
- NEVER wrap the release cable around your hand, fingers, or any other part of your body!
- DO NOT allow people to ride on or in the hopper.
- DO NOT use the hopper if any label is unreadable or missing. Apply replacement labels before returning the hopper to service. See [LABELING DIAGRAM](#) on p. 9.
- ALWAYS apply proper lift truck operation techniques learned during your training program. Before raising the hopper from the floor, tilt the (forklift) mast toward the cab of the truck to ensure that the hopper will not slide off of the forks.
- DO NOT modify the hopper without first obtaining written approval from Vestil. Unapproved modifications might make the hopper unsafe to use and automatically void the [LIMITED WARRANTY](#) on p. 10.
- DO NOT dump the hopper UNLESS everyone in the vicinity is a safe distance away from the dumping site.
- DO NOT dump the hopper if the forklift is on sloped terrain. Only dump the hopper while on even, level surfaces.
- DO NOT exceed the load ratings or fill the hopper above the side walls. Injury to personnel or permanent damage to the equipment could result from overloading.
- ALWAYS engage the caster brake when the hopper is stationary or not in use.

NOTE: US Federal OSHA rule 29 CFR 1910.178(m)(5)(iii), requires operators of powered trucks to fully lower the "load engaging means" (forks), neutralize truck controls, and set brakes whenever they dismount a lift truck and remain within 25ft of it. This self-dumping hopper allows lift truck operators to remain at the controls of their trucks throughout the dumping process.

HOP-LP EXPLODED VIEW AND BILL OF MATERIALS

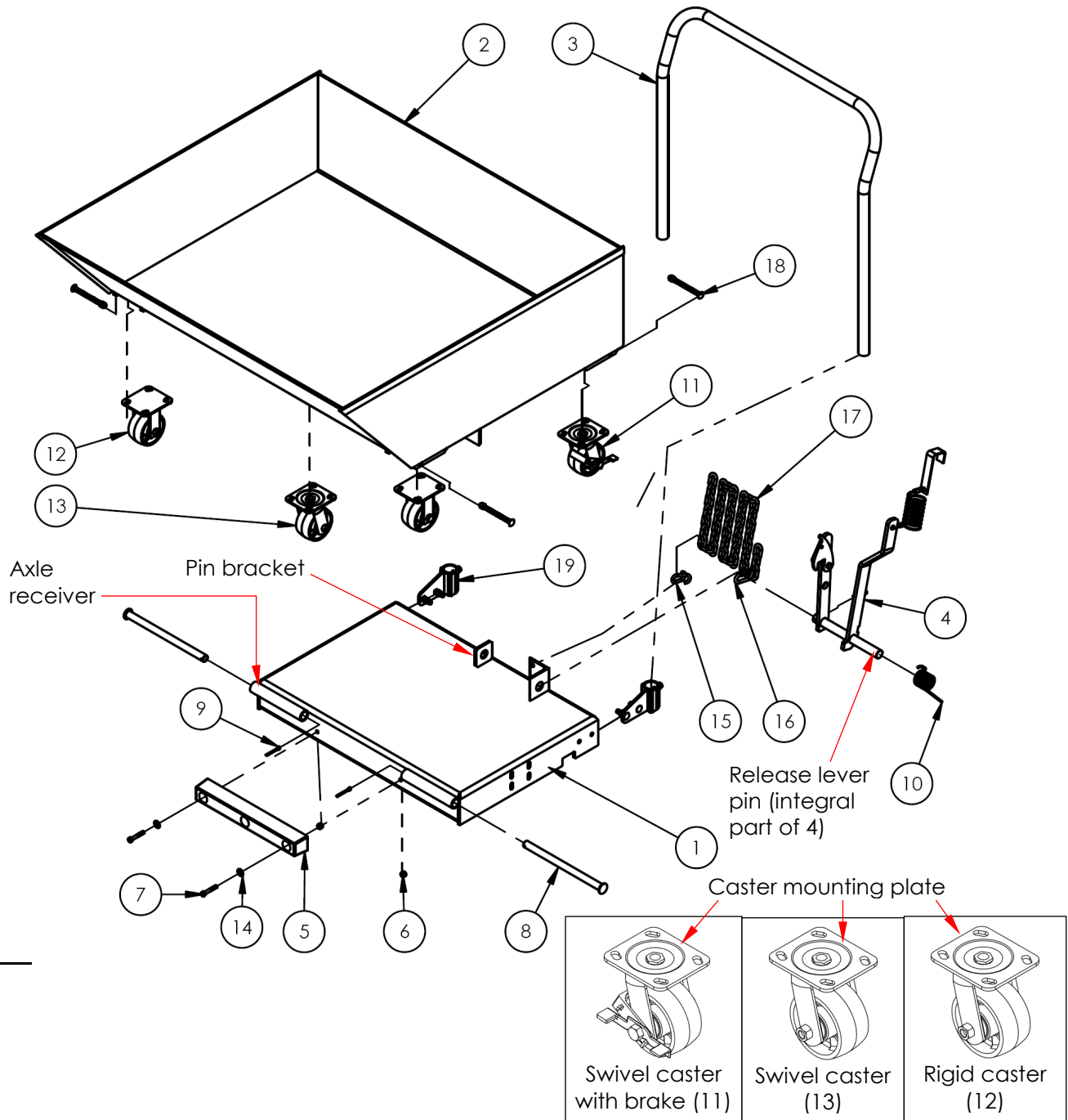

Item	Part no.	Description	Qty.	Item	Part no.	Description	Qty.
1	37-514-083	WELDMENT, FRAME, BASE	1	11	16-132-259	Caster, swivel, with brake, GFN-4/2-SWB	1
2	37-545-028	WELDMENT, CHUTE	1	12	16-132-260	Caster, rigid, GFN-8/2-R caster	2
3	37-025-007	CHUTE, HANDLE	1	13	16-132-258	Caster, swivel, GFN-8/2-S	1
4	37-537-021	WELDMENT, LOCK, RELEASE LEVER ASSEMBLY	1	14	33006	5/16" zinc-plated USS flat washer	2
5	29-048-061	BUMPER, RUBBER	1	15	99-145-084	Lap link	1
6	37021	NYLON INSERT LOCK NUT, GRADE 2, ZINC FINISH, 5/16"-18	2	16	99-145-053	5/16" quick link	1
7	11061	HHCS #2 Z PLATED, GRADE A, Ø 5/16 - 18 x 2" LG	2	17	09-145-018	5/16" chain, 56" long	1
8	37-112-045	PIN, HINGE AXLE	2	18	99-112-006 65076	Pin, clevis, 0.374" x 4-5/8" Pin, cotter, 1/8" x 1"	4 4
9	65127	COTTER PIN Z PLATED, 3/16 x 2	3	19	37-154-022	Kit, handle socket bracket	1
10	37-146-005	SPRING, TORSION, HOPPER RELEASE	1				

USING THE CASTER BRAKE

Each HOP-LP-series hopper has 2 swiveling casters in back, one of which is equipped with a brake. To engage the brake, press the brake lever down. When the brake is engaged, the wheel will not rotate. To disengage the brake, lift the brake lever up.

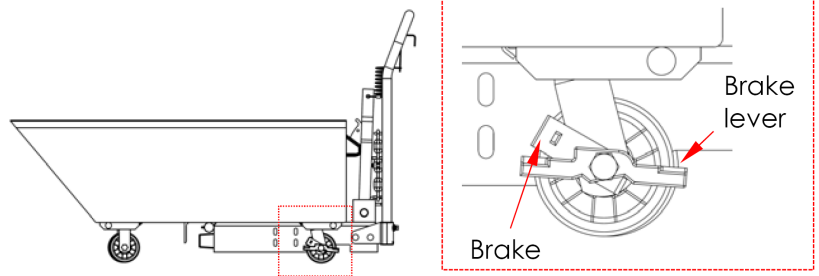

ASSEMBLING THE HOPPER

Wear gloves while assembling this product. Assembly consists of installing the handle and the casters.

1. [Refer to [LOADING & USING THE HOPPER](#), steps 1-3 & 5 on p. 7 - 8.]

Insert the forks of your lift truck into the fork pockets of the hopper. Wrap the safety chain around the fork carriage and attach the quick link to the chain. There should be no slack in the chain. Lift the hopper and bring the base frame to a comfortable working height; then dump the chute.

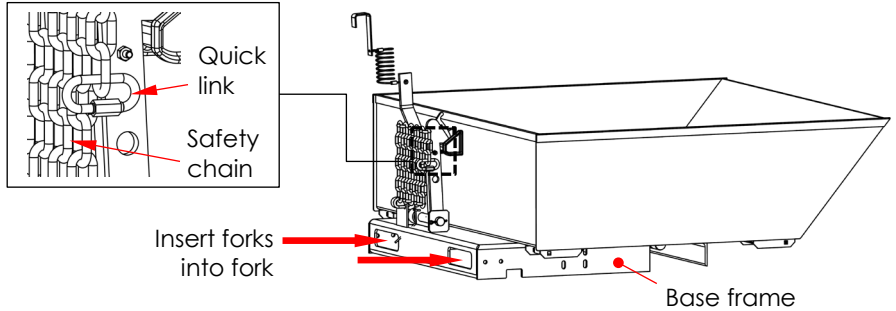

2. Install the handle: a) Attach the handle socket kit ([EXPLODED VIEW, item no. 19 on p. 4](#))--Bolt the left and right handle sockets onto the base frame by inserting $\frac{3}{8}$ " - 16 UNC x $1\frac{1}{2}$ " carriage bolts through the 2 lower bolt holes in each bracket; b) insert the bolts through the 2 bolt holes in the base frame; c) Secure each bolt with a $\frac{3}{8}$ " lock nut; then d) Insert the handle legs into the sockets as shown below and tighten the $\frac{3}{8}$ " - 16 x $\frac{3}{4}$ " set screws against the legs.

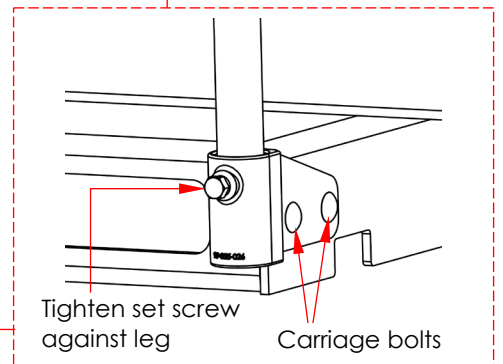
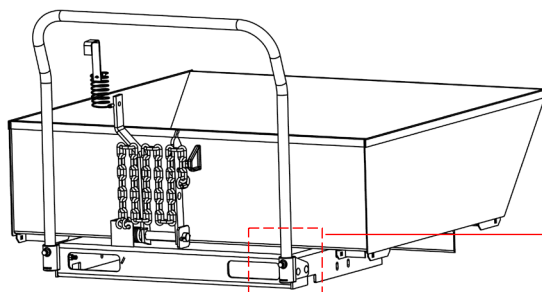
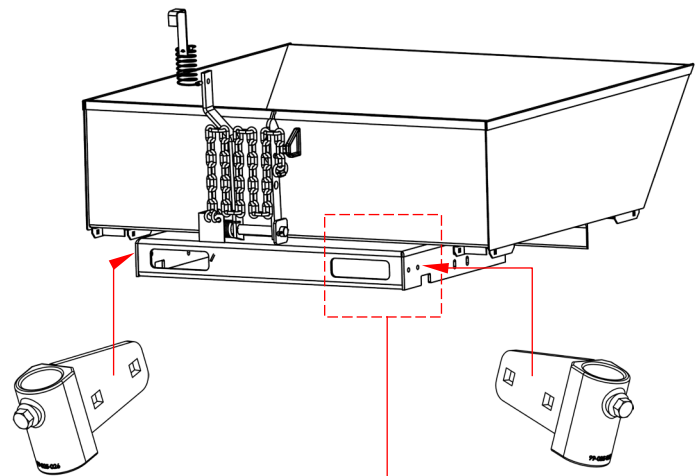
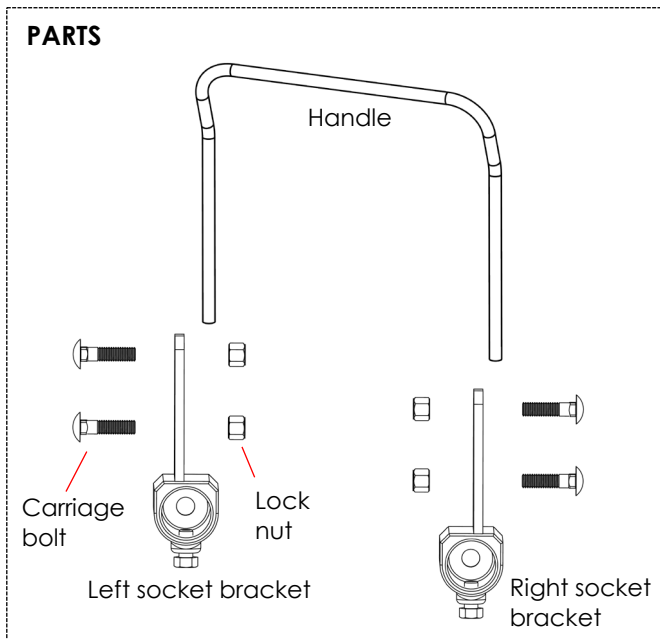

3. To install the casters, follow steps A & B as diagrammed below. Refer to the [EXPLODED VIEW on p. 4](#) to properly identify casters. [NOTE: The chute should still be in the dumped position.]

Underside of hopper:

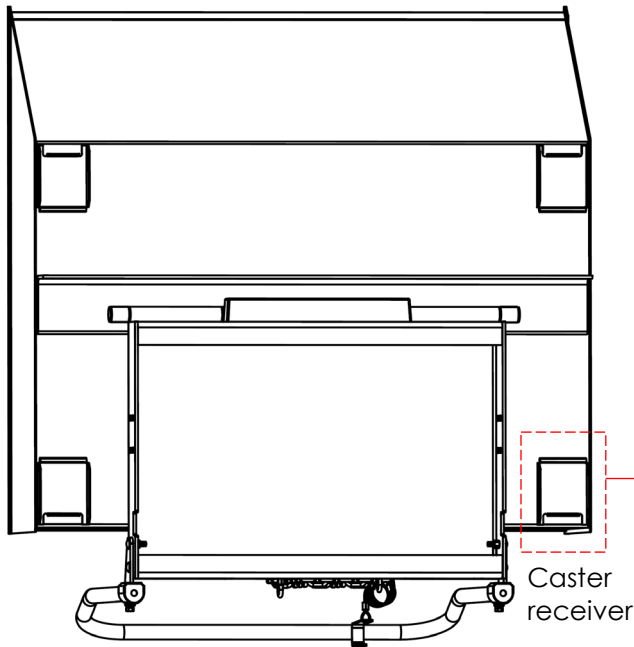

Parts of caster receiver:

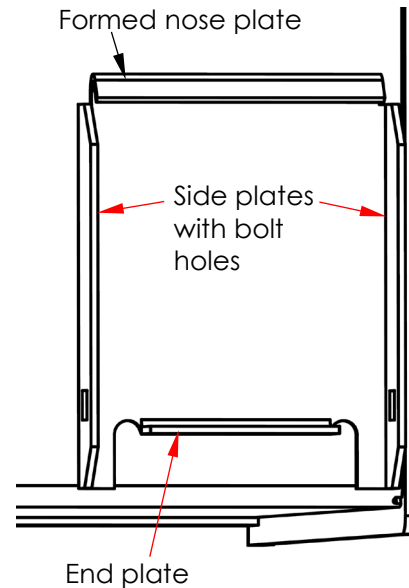

Step A: Insert one edge of the caster mounting plate under the formed nose plate of the caster receiver. Press the mounting plate against the underside of the hopper.

Step B: Insert $4\frac{5}{8}$ in. clevis pins (99-112-006) through the holes in the receivers. Insert the clevis pins through the inside holes (see dashed arrows in diagram). Secure the clevis pins with $\frac{1}{8}$ in. – 1" cotter pins (65076).

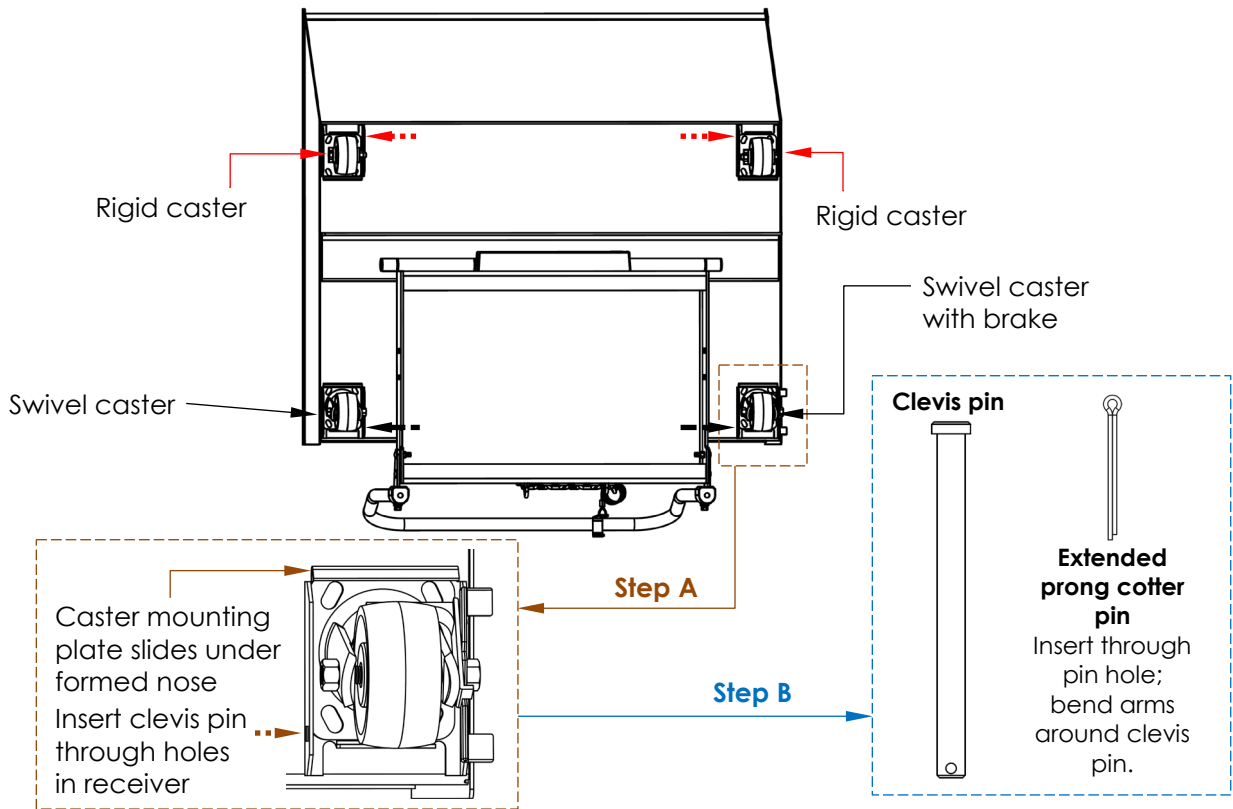

Step 4 [See Diagram 1 on p. 7]: Lower the forks until the hopper rests on the ground. The chute will pivot towards the frame. Press the back end of the chute onto the base until the latch lever engages the latch bar. Push the finger tab at the top end of the latch lock bracket until the bracket engages the latch bar.

LOADING & USING THE HOPPER

⚠ WARNING

Do not exceed the load rating or fill the hopper above the top of the sides. Serious personal injury (or property damage) could result from overloading the hopper.

Loading the Hopper

Confirm that the hopper chute is solidly latched to the base frame before filling the chute with refuse. Standard units are designed for indoor and outdoor use in most industrial and commercial settings. They should only be used to collect and dump non-hazardous wastes. Whenever the hopper is stationary, engage the [caster brake](#). See [USING THE CASTER BRAKE](#) on [p. 5](#).

Using the Hopper

1. Mount the hopper on the forks of a lift truck and secure it to the carriage with the safety chain. Wrap the free end of the chain around the lift carriage; then fasten the quick link to a link in the chain. The chain must be taut (no slack) to prevent the hopper from sliding on the forks.
2. Store the handle of the release cable within reach of the forklift operator. For example, hook the cable to the frame of the forklift cab. Make sure that there is plenty of slack in the cable to avoid accidentally releasing the chute.
3. The chute cannot dump unless the latch is unlocked. To unlock the latch, pull the finger tab at the top end of the latch lock bracket until the bracket disengages the latch bar. See [Diagram 1](#) (below).
4. Raise the hopper above the dumpster and drive forward until the dumping axis (dotted line) is clearly over the inside of the dumpster as shown in Diagram 2 below.

Diagram 1: Unlock the latch

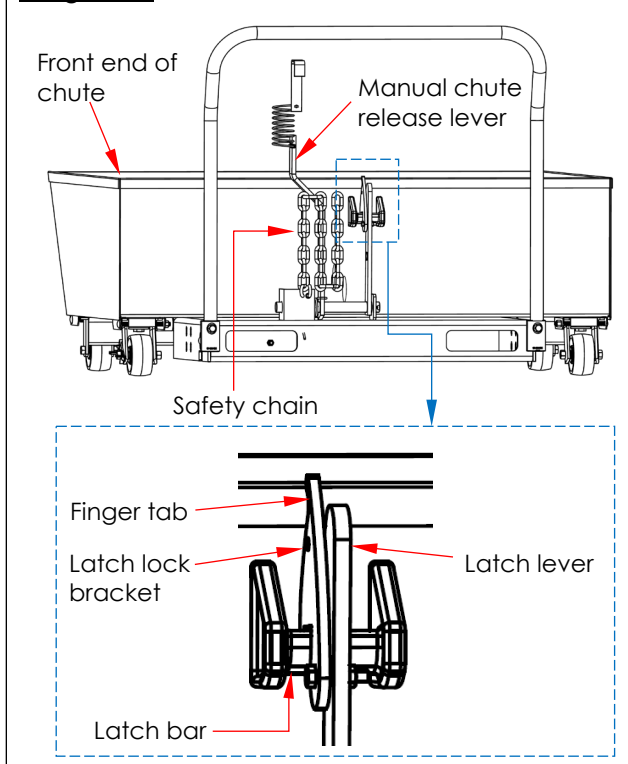
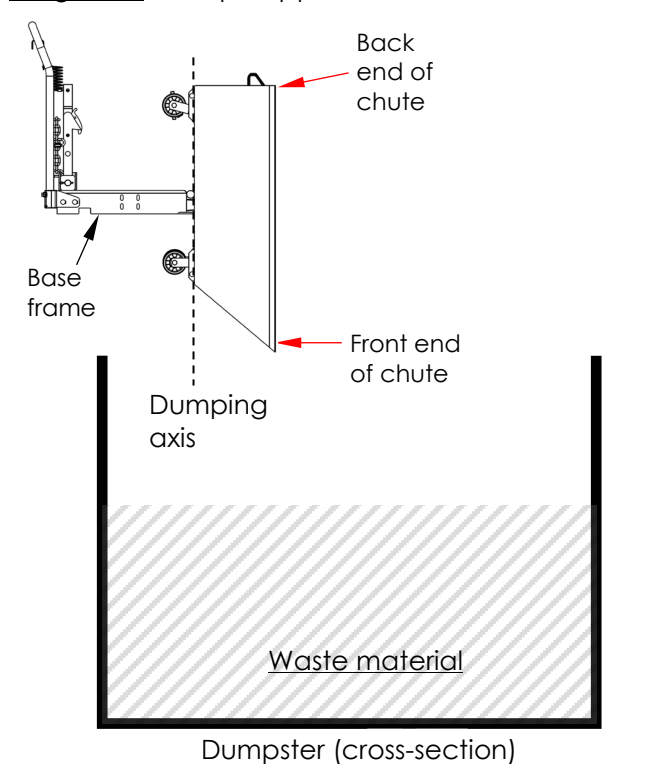

Diagram 2: Dump hopper contents



5. Dump the contents of the hopper by releasing the chute. To release the chute, pull the release cable. The chute will pivot about the dump axis.

⚠ WARNING

DO NOT wrap the release cable around your hand/fingers or attach the handle to your clothing!

6. Latch the chute to the base.
 - a. Manually: slowly lower the forks until the hopper rests on the ground. The chute will pivot towards the frame. Press the back end of the chute onto the base until the latch lever engages the latch bar. See [Diagram 1](#).
 - b. Using the forklift: raise the fork tips by tilting the forklift mast toward the cab. Then, back away from the dumpster. Slowly lower the forks until the front end of the chute contacts to top of the side of the

dumpster. Continue to slowly lower the forks until the chute pivots onto the base frame. You should hear the latch lever snap over the latch bar. Confirm that the chute is securely latched by raising the forks. The chute should not rotate. If necessary, lower the forks completely and manually latch the chute to the frame.

7. Lock the latch by reversing the process described in [step 3](#). DO NOT move the hopper until the latch is locked!

RECORD OF SATISFACTORY CONDITION (THE "RECORD")

Before using this hopper for the first time, create a record of its appearance and features. Include descriptions of the chute, handle, base, carriage chain and quick link, pivot points and pivot point hardware, and the chute release mechanism. Release the chute. Describe how the unit looks and sounds as the chute rotates. Also describe the force necessary to release the chute by hand using both the manual release lever and the release cable. Secure the chute to the base and describe how the latch mechanism works. Thoroughly photograph the unit including all labels. Collate all writings and photographs into a single file. This file is a record of the unit in satisfactory condition. **Compare the results of all inspections to this RECORD to determine if the unit is in satisfactory condition.** Restore the hopper to satisfactory condition BEFORE using it again. Purely cosmetic changes, like damaged surface finish (paint or powdercoat) are not changes from satisfactory condition. However, touchup paint should be applied as soon as damage occurs to prevent rusting.

INSPECTIONS & MAINTENANCE

Inspections and repairs should only be performed by qualified persons. Compare the results of each inspection to the [RECORD OF SATISFACTORY CONDITION](#) (the "RECORD"). Do not use the hopper unless all parts are in satisfactory condition. Replace parts that are not in satisfactory condition before using the hopper again. **DON'T GUESS! If you have any questions about the condition of your hopper, speak with TECHNICAL SERVICE personnel.** The phone number is provided on the cover page of this manual. **Never make temporary repairs of damaged or missing parts.** Only use manufacturer-approved replacement parts.

Inspections [refer to [EXPLODED VIEW](#) on p. 4]:

(A) Before each use inspect the following components:

- 1.) Release cable – Look for fraying, birdcaging, thinning.
- 2.) Hopper chute or base frame – Check for damage, deformation, corrosion or severely rusted regions.
- 3.) Pivot points – As the chute rotates (after releasing it), listen for unusual noise and watch for binding as the chute rotates. Also look for distortion of the axle pins or axle receivers.
- 4.) Release/Latch mechanisms – Test the chute release mechanism ("[lock release, lever assembly](#)"). The torsion spring should cause the lever assembly to automatically recoil and firmly latch the chute to the frame.
- 5.) Safety chain – Check the chain for damaged links (broken, cracked, elongated).

(B) Inspect the following components at least once per month:

- 1.) Pivot points – Look for excessive wear, warping, or other damage to the release lever pin, pin brackets, axle pins, and axle receivers. Listen for unusual noises and watch for irregular movement. Remove dirt and debris from areas that could affect the hopper's dumping motion.
- 2.) Fasteners (bolts, nuts, axle pins, cotter pins, retaining rings) – Inspect for looseness and wear.
- 3.) Casters – Check for looseness, excessive wear, or damage to the casters, caster bearings, mounting brackets, and hardware. Confirm that the brake functions properly.
- 4.) Release mechanism – Verify that the mechanisms function properly: 1) torsion spring firmly latches the lock release lever assembly ("[lever assembly](#)") to the chute; 2) the latch lock bracket should seat on the latch bar unless manually disengaged (see [Diagram 1](#) on p. 7); 3) lever assembly pivots smoothly and securely engages the latch bar.
- 5.) Chute – Examine the chute. The structure should be rigid and square without corroded holes or severely rusted areas.
- 6.) Supporting frame – Examine the frame. It should be rigid and square, welds should be intact, and fork pockets should be square and sound.
- 7.) Labels – All labels must be in the locations shown in the [LABELING DIAGRAM](#) on [p. 9](#).

Maintenance:

Implement a maintenance program to ensure that the product functions properly.

Step 1: Tag the hopper, "Out of Service."

Step 2: Remove dirt and debris from all surfaces.

Step 3: Conduct the scheduled inspection. If deformity, corrosion, rusting, or excessive wear of the frame or chute is discovered, remove it from service.

Step 4: Perform all necessary adjustments, replacements and/or repairs, but DO NOT modify the hopper.

Step 5: Make a dated record of any repairs, adjustments, and/or replacements.

LABELING DIAGRAM

The unit should be labeled as shown in the diagram. However, label content and location are subject to change so your product might not be labeled exactly as shown. Thoroughly photograph the unit when you first receive it as discussed in the [RECORD OF SATISFACTORY CONDITION](#) section on p. 9. Make sure that your record includes a photograph of each label. Replace all labels that are, or later become, damaged, missing, or not easily readable (e.g. faded). To order replacement labels, contact the [TECHNICAL SERVICE AND PARTS DEPARTMENT](#) online at http://www.vestilmfg.com/parts_info.htm. Alternatively, you may call (260) 665-7586 and ask the operator to connect you to the [PARTS DEPARTMENT](#).

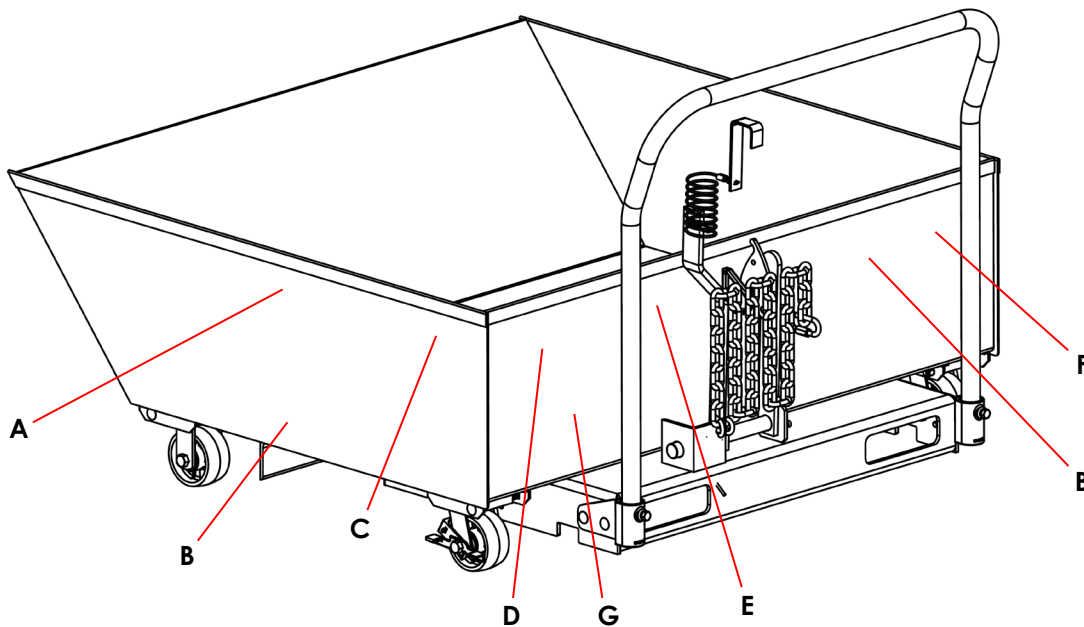

A: Label 375 (both sides)

⚠ WARNING	⚠ ADVERTENCIA	⚠ AVERTISSEMENT
DO NOT PLAY ON OR AROUND	NO JUEGE ALREDEDOR	NE PAS JOUER SUR OU AUTOUR DE L'UNITÉ

B: Label 208 (both sides & back)

⚠ WARNING	⚠ ADVERTENCIA	⚠ AVERTISSEMENT
KEEP CLEAR OF PINCH POINT	MANTENGASE ALEJADO DEL PUNTO DE CORTE	SE TENIR À DISTANCE DU POINT DE PINCEMENT

C: Label 220 (both sides)

⚠ WARNING	⚠ ADVERTENCIA	⚠ AVERTISSEMENT
KEEP CLEAR WHEN IN USE	MANTENGASE ALEJADO CUANDO SE ESTA OPERANDO	SE TENIR À DISTANCE LORS DU FONCTIONNEMENT

D: Label 995

⚠ WARNING	⚠ ADVERTENCIA
DO NOT use this product to lift or transport people.	NO use este producto para transportar o elevar personas.

E: Label 620

⚠ WARNING
DO NOT wrap release cable around hand. Severe injury or amputation might occur if cable wrapped around body part when chute dumped.
STAY CLEAR of hopper when dumping. DO NOT hook manual release handle on hopper when using bumper release. Each person who uses this hopper should have access to the user manual. Copies of the manual can be downloaded from www.vestil.com .
⚠ ADVERTENCIA
NO AGARRAR el cable con la mano. Puede causar un daño severo o amputación si el cable se envuelve alrededor del cuerpo al estar descargando la tolva. MANTENTE ALEJADO de la tolva al descargar. Nunca agarrar el gancho de la tolva. Cada persona que use la tolva debe de usar el manual, las copias se pueden descargar de la dirección www.vestil.com .

F: Label 549 (on back)

Model / Modelo / Modèle	⚠ WARNING	⚠ ADVERTENCIA
Capacity / Capacidad / Capacite _____ lbs. _____ kgs.	<ul style="list-style-type: none"> SECURELY ATTACH safety restraint to forklift Tilt load backwards to prevent hopper from sliding Distribute load evenly DO NOT exceed rated capacity Hopper MUST be locked when not dumping Disengage lock on hopper release before dumping hopper DO NOT wrap release cable around any body part 	<ul style="list-style-type: none"> ASEGURE la cadena de seguridad a la transpaleta Vuelque la carga hacia atrás para prevenir que el carrito resbale Distribuya la carga uniformemente NO exceda la capacidad de carga tasada El depósito de alimentación debe ser cerrado al no descargar Suete cerradura en la liberación de depósito de alimentación antes de descargar depósito de alimentación No envuelva cable de liberación alrededor de cualquier parte del cuerpo
Serial No. / Serie No. / Serie No.	549 REV 1011	

G: Label 419

BEFORE ACCEPTING DELIVERY
INSPECT each package RECORD any damage on Bill of Lading VERIFY number of packages
SHIPPER is NOT RESPONSIBLE for any DAMAGE or SHORTAGES unless indicated on the Bill of Lading.

LIMITED WARRANTY

Vestil Manufacturing Corporation ("Vestil") warrants this product to be free of defects in material and workmanship during the warranty period. Our warranty obligation is to provide a replacement for a defective, original part covered by the warranty after we receive a proper request from the Warrantee (you) for warranty service.

Who may request service?

Only a warrantee may request service. You are a warrantee if you purchased the product from Vestil or from an authorized distributor AND Vestil has been fully paid.

Definition of "original part"?

An original part is a part used to make the product as shipped to the Warrantee.

What is a "proper request"?

A request for warranty service is proper if Vestil receives: 1) a photocopy of the Customer Invoice that displays the shipping date; AND 2) a written request for warranty service including your name and phone number. Send requests by one of the following methods:

<u>US Mail</u>	<u>Fax</u>	<u>Email</u>
Vestil Manufacturing Corporation 2999 North Wayne Street, PO Box 507 Angola, IN 46703	(260) 665-1339 <u>Phone</u> (260) 665-7586	info@vestil.com Enter "Warranty service request" in subject field.

In the written request, list the parts believed to be defective and include the address where replacements should be delivered. After Vestil receives your request for warranty service, an authorized representative will contact you to determine whether your claim is covered by the warranty. Before providing warranty service, Vestil will require you to send the entire product, or just the defective part (or parts), to its facility in Angola, IN.

What is covered under the warranty?

The warranty covers defects in the following original, dynamic parts: motors, hydraulic pumps, motor controllers, and cylinders. It also covers defects in original parts that wear under normal usage conditions ("wearing parts"), such as bearings, hoses, wheels, seals, brushes, and batteries.

How long is the warranty period?

The warranty period for original dynamic components is 90 days. For wearing parts, the warranty period is 90 days. Both warranty periods begin on the date Vestil ships the product to the Warrantee. If the product was purchased from an authorized distributor, the periods begin when the distributor ships the product. Vestil may, at its sole discretion, extend a warranty period for products shipped from authorized distributors by up to 30 days to account for shipping time.

If a defective part is covered by the warranty, what will Vestil do to correct the problem?

Vestil will provide an appropriate replacement for any covered part. An authorized representative of Vestil will contact you to discuss your claim.

What is not covered by the warranty?

The Warrantee (you) are responsible for paying labor costs and freight costs to return the product to Vestil for warranty service.

Events that automatically void this Limited Warranty.

- Misuse;
- Negligent assembly, installation, operation or repair;
- Installation/use in corrosive environments;
- Inadequate or improper maintenance;
- Damage sustained during shipping;
- Collisions or other accidents that damage the product;
- Unauthorized modifications: Do not modify the product IN ANY WAY without first receiving written authorization from Vestil.

Do any other warranties apply to the product?

Vestil Manufacturing Corp. makes no other express warranties. All implied warranties are disclaimed to the extent allowed by law. Any implied warranty not disclaimed is limited in scope to the terms of this Limited Warranty. Vestil makes no warranty or representation that this product complies with any state or local design, performance, or safety code or standard. Noncompliance with any such code or standard is not a defect in material or workmanship.